

Drawing #: 60218-WKC
60218 Keyboard Clamp Custom Assembly

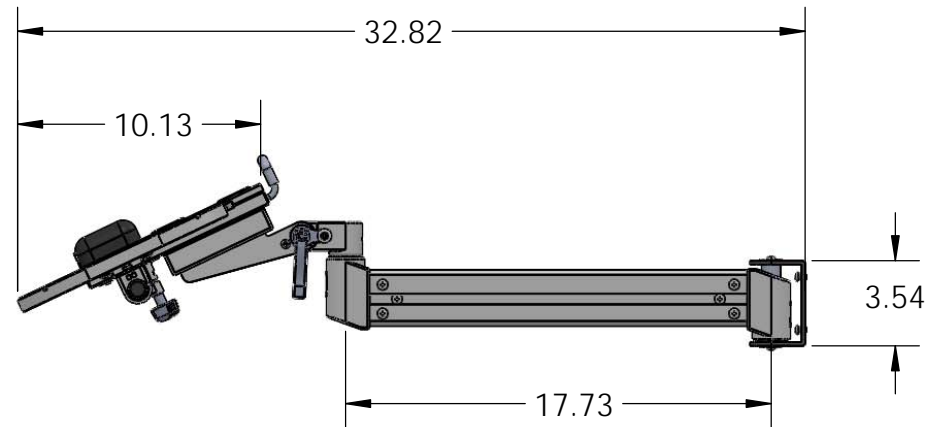
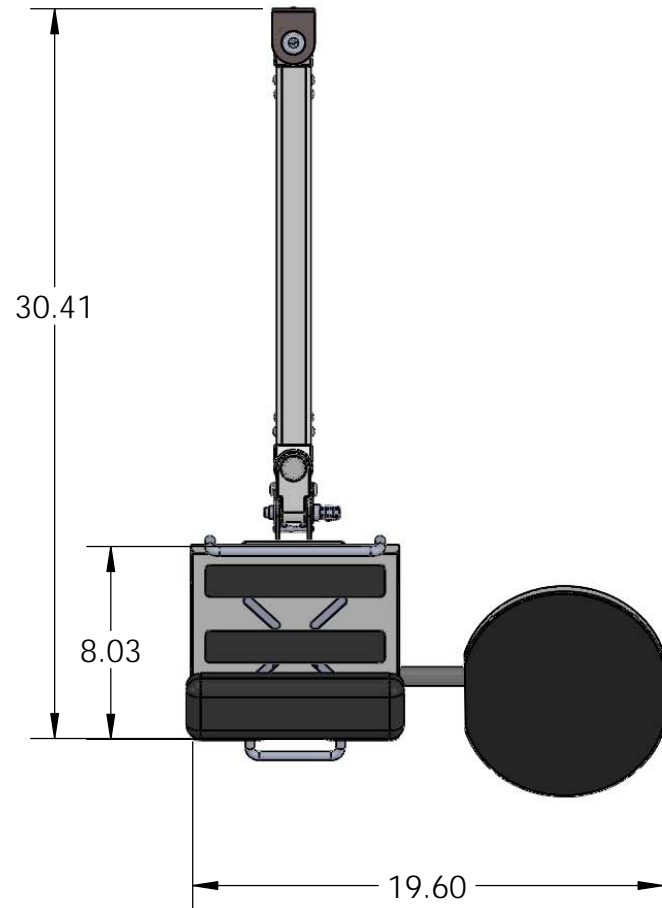

PROPRIETARY AND CONFIDENTIAL
THE INFORMATION CONTAINED IN THIS DRAWING IS THE SOLE PROPERTY OF CUSTOM PRODUCTS AND SERVICES. ANY REPRODUCTION IN PART OR AS A WHOLE WITHOUT THE WRITTEN PERMISSION OF CUSTOM PRODUCTS AND SERVICES IS PROHIBITED.

		UNLESS OTHERWISE SPECIFIED:		NAME	DATE		
		DIMENSIONS ARE IN INCHES	DRAWN	NJN	6-30-16	TITLE: Custom 60218	
		TOLERANCES:	CHECKED				
		FRACTIONAL ±	ENG APPR.				
		ANGULAR: MACH ± BEND ±	MFG APPR.				
		TWO PLACE DECIMAL ±	Q.A.			SIZE	DWG. NO.
		THREE PLACE DECIMAL ±	COMMENTS:		A		
		INTERPRET GEOMETRIC TOLERANCING PER:				SCALE: 1:12	WEIGHT:
		MATERIAL					
		FINISH					
NEXT ASSY	USED ON						
APPLICATION		DO NOT SCALE DRAWING					

5

4

3

2

1